

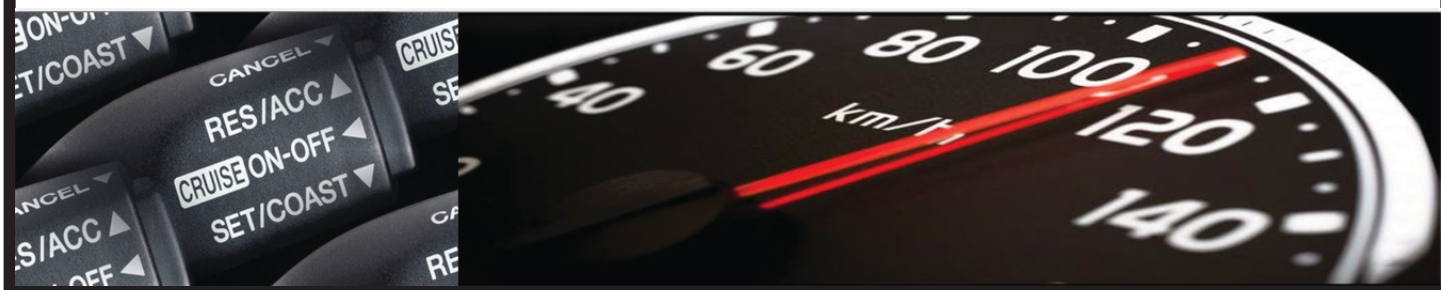

Quick installation manual

Cruise Control

AP500



1. PARTS LIST

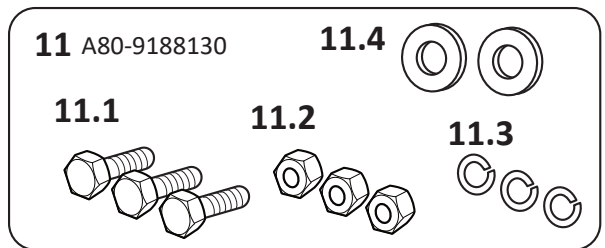
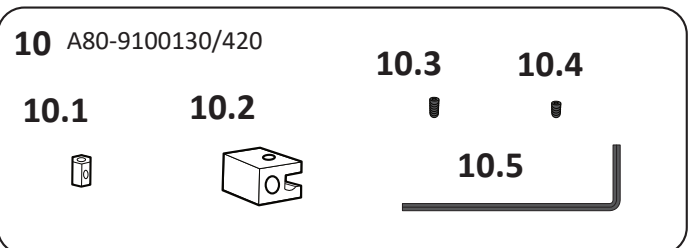
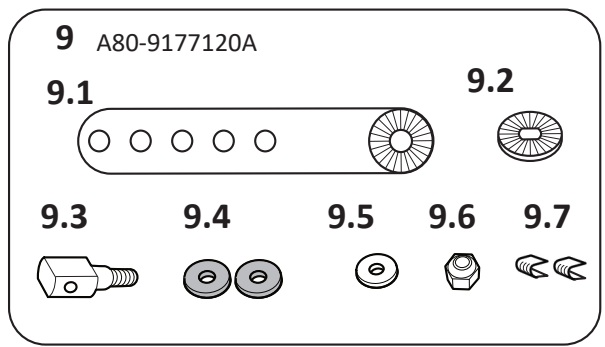
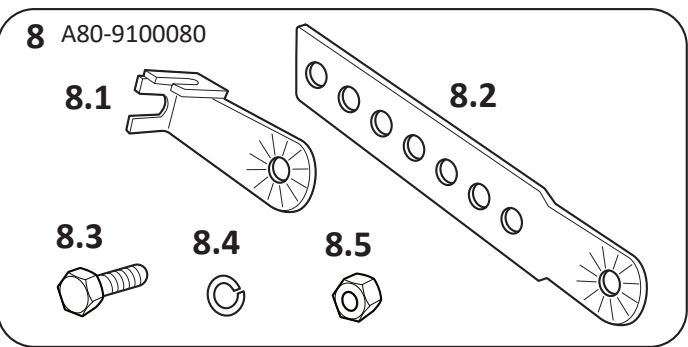
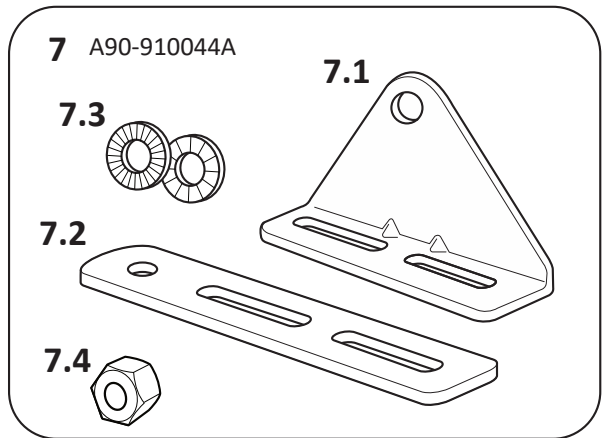
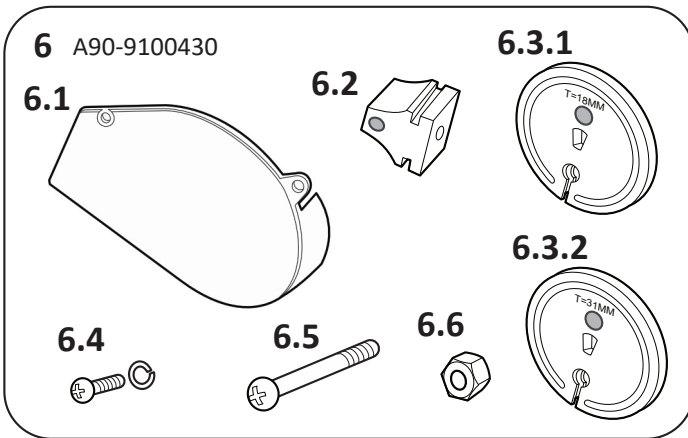
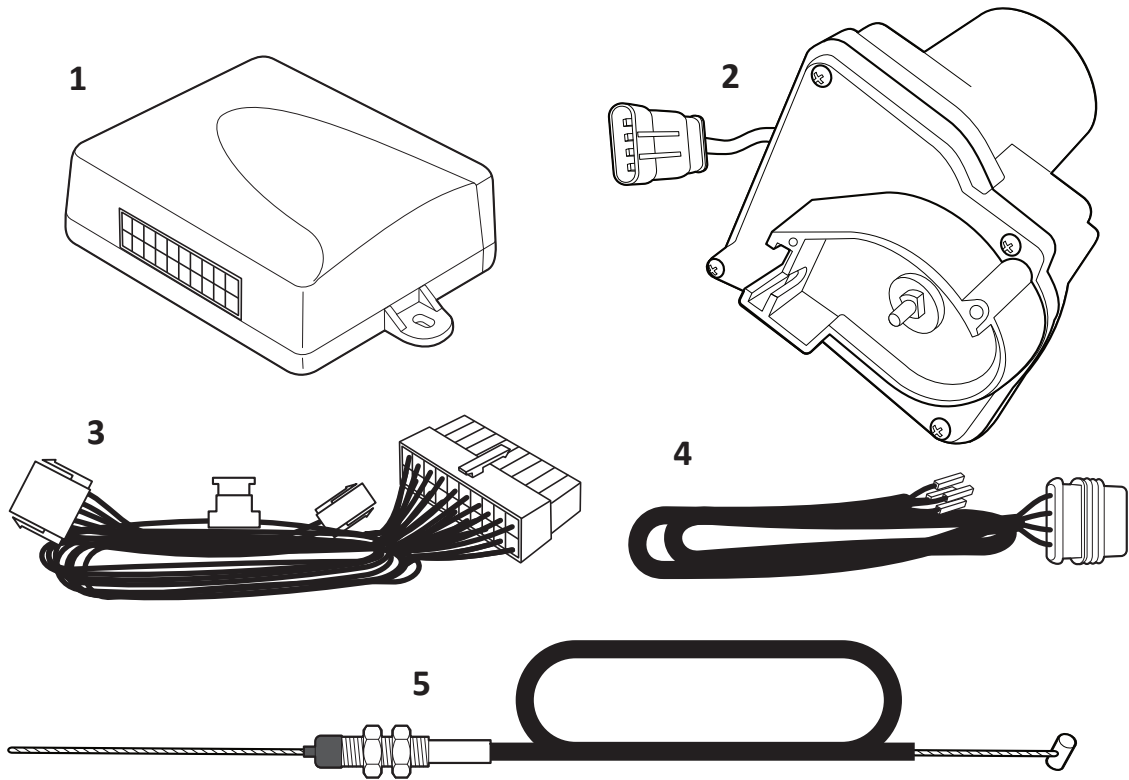

Item No.	Part No.	Qty.	Description
1	A10-2086930	1	Electronic module AP500 EVO
2	LTK-040092A	1	Electric servo AP500 EVO
3	190-500001A	1	Main wiring harness
4		1	Servo wiring harness
5	241.000010C	1	Servo cable AP500 EVO
6	A90-9100430		
6.1		1	Servo cover
6.2		1	Triangular block with yellow and red dots
6.3.1		1	Pulley with yellow dot: stroke 24 and 18mm
6.3.2		1	Pulley with red dot: stroke 38 and 31 mm
6.4		1	Bolt M3x12 with spring washer
6.5		1	Screw 4x40
6.6		1	M6 lock nut
7	A90-910044A		
7.1		1	Bracket for servo
7.2		1	Bracket for servo
7.3		2	Lock washer M10
7.4		1	M10 nut
8	A80-9100080		
8.1		1	Cable bracket
8.2		1	Extension of cable bracket
8.3		1	Bolt M6x15
8.4		1	Spring washer M6
8.5		1	Nut M6
9	A80-9177120A		
9.1		1	Throttle pulley adaptor
9.2		1	Lock washer
9.3		1	Swivel bolt
9.4		2	Nylon washer M4
9.5		1	Washer M4
9.6		1	Lock nut M4
9.7		2	Metal clip
10	A80-9100130/420		
10.1		1	End clamp
10.2		1	Cable clamp
10.3		1	M4x4 hexagonal bolt
10.4		1	M4x6 hexagonal bolt
10.5		1	Allen key
11	A80-9188130		
11.1		3	Bolt M6x15
11.2		3	Nut M6
11.3		3	Spring washer M6
11.4		2	Wide washer M6
		4	Zip tie 2.6x90mm
		1	Biadeshive tape 75x75mm
		1	Installation manual
		1	User manual

2. MAIN WIRING DIAGRAM

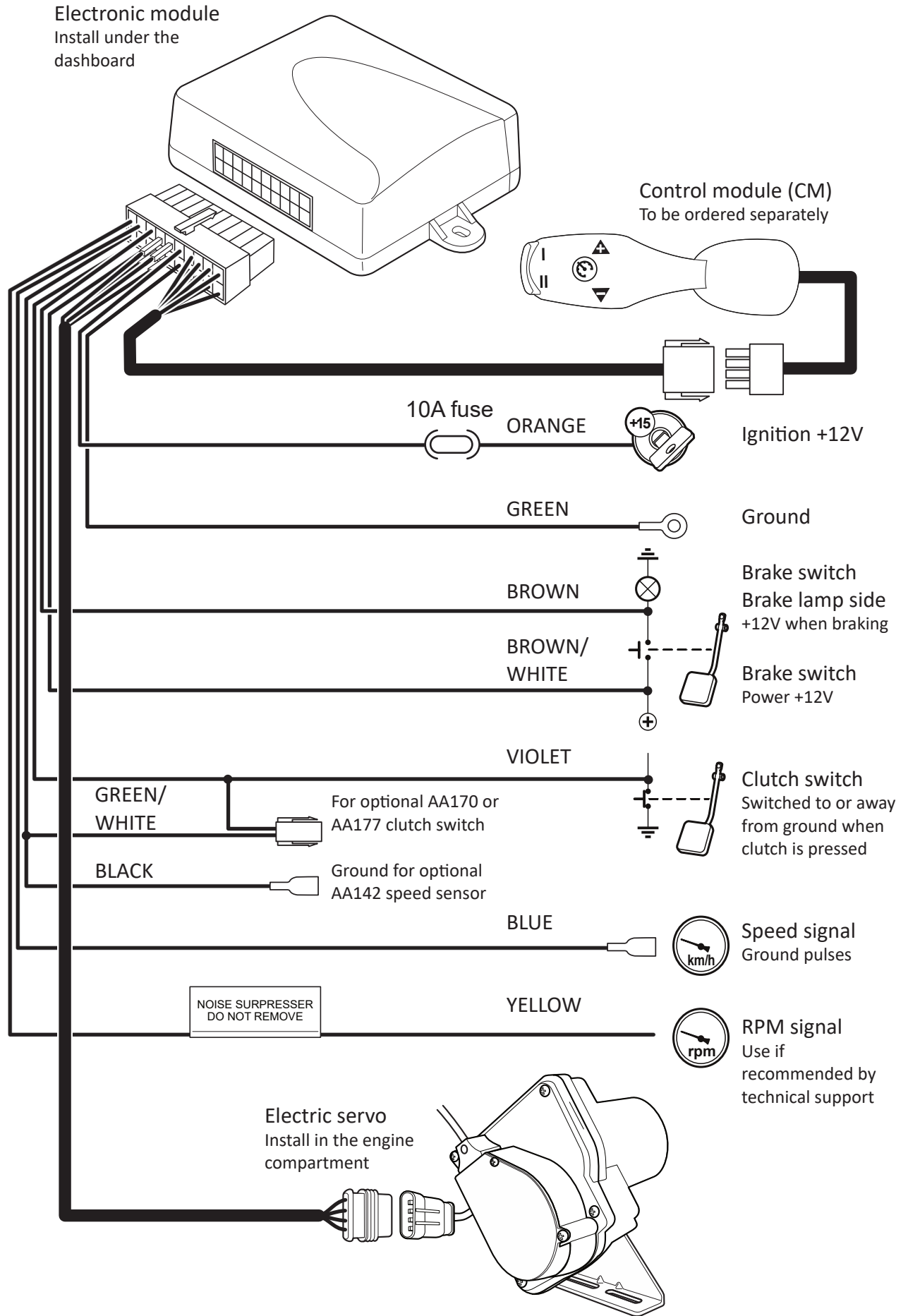

3. SERVO CABLE CONNECTION

3.1 General instructions

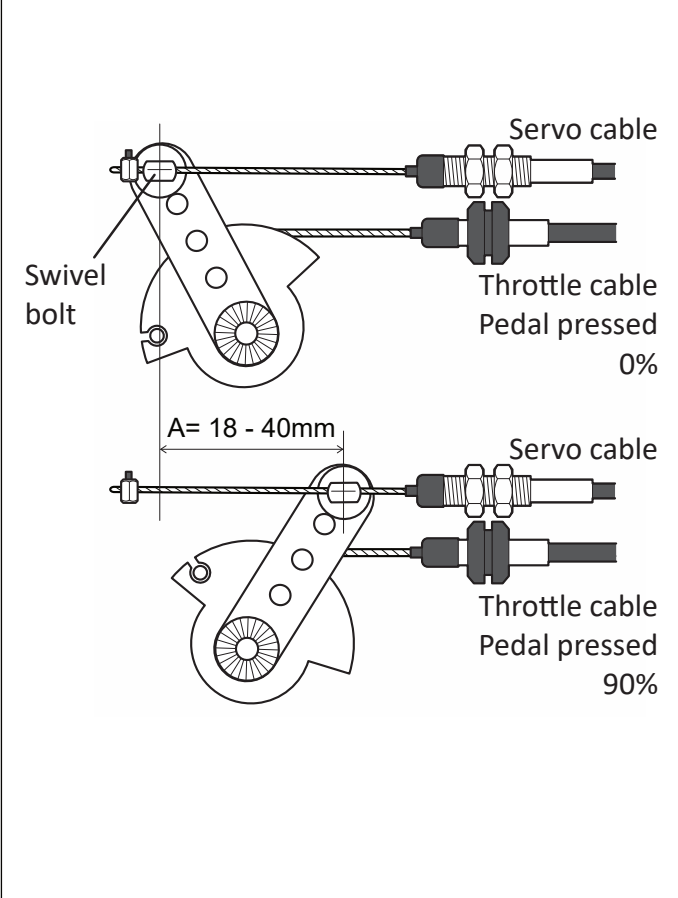
 <p>The diagram illustrates the connection between a servo cable and a throttle cable. It shows two states: 'Pedal pressed 0%' and 'Pedal pressed 90%'. A dimension 'A = 18 - 40mm' is shown between the swivel bolt and the servo cable attachment point. Labels include 'Swivel bolt', 'Servo cable', and 'Throttle cable'.</p>	<p>Find a connection point in the throttle mechanism where the cruise control cable stroke A is between 18 and 40 mm when throttle pedal is pressed from 0 to about 90%. Throttle cable stroke must always be longer than stroke of servo cable!</p> <p>When accelerating with the foot, the servo inner cable should not be pushed into the outer cable but should slide through the swivel bolt 9.3 or aluminium block 10.2.</p> <p>The throttle cables must not be able to become blocked or entangled in any way, as this may result in the throttle/diesel pump not returning to idle!!! Give to servo cable a little slack in the idle position. Adjust the servo cable with the engine warm because of any cold-start device.</p> <p>Final installation of cable is only when the cable is attached to servo!</p>
---	--

3.2 Servo cable attachment to the throttle pulley

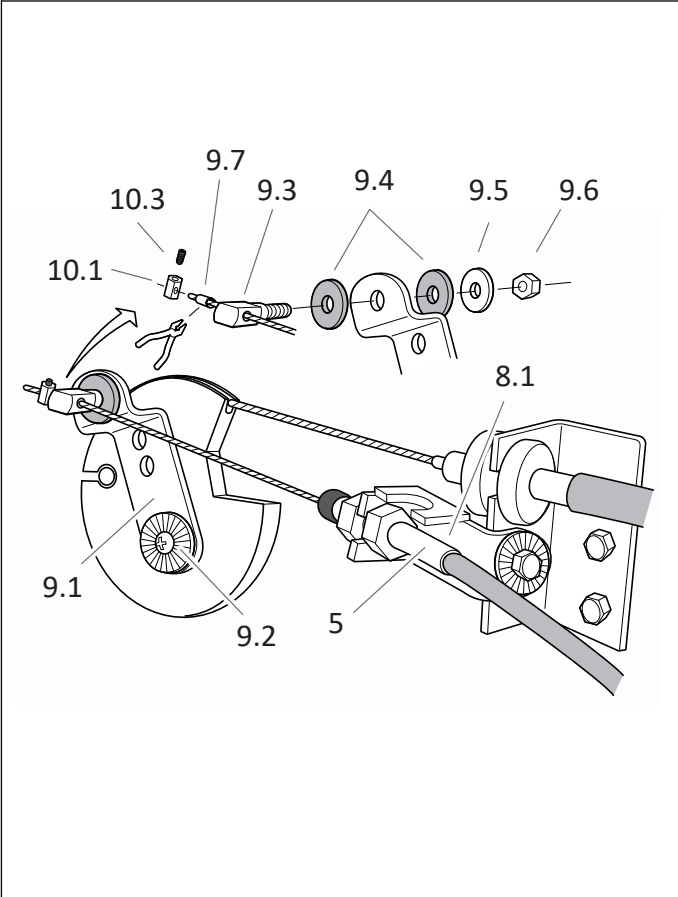
 <p>The diagram shows the assembly of the servo cable attachment. Components are labeled with numbers: 10.3 (bolt), 9.7 (U-shaped metal clip), 9.3 (swivel bolt), 9.4 (nylon washer), 9.5 (washer), 9.6 (lock nut), 10.1 (end clamp), 9.1 (throttle pulley adaptor), 9.2 (throttle pulley), 5 (servo cable), and 8.1 (cable bracket).</p>	<p>Determine the most suitable throttle linkage. Mount cable bracket 8.1. It can be used as one piece or with extension 8.2 or bent and trimmed in numerous ways.</p> <p>Mount throttle pulley adaptor 9.1 to the pulley and attach swivel bolt 9.3 with nylon washers 9.4, washer 9.5 and lock nut 9.6 to the adaptor so that it could freely swivel allowing servo cable to slide straight through in any position of throttle mechanism.</p> <p>After cable is attached to the servo, attach servo cable 5 to cable bracket 8.1, push the inner cable through the hole of swivel bolt 9.3, install U shaped metal clip 9.7 to the location where will be installed end clamp 10.1 and press it with pliers around the inner cable, install end clamp 10.1 and fix it with bolt 10.3 so that bolt will press against metal clip.</p>
--	--

3.2 Servo cable attachment to the throttle cable

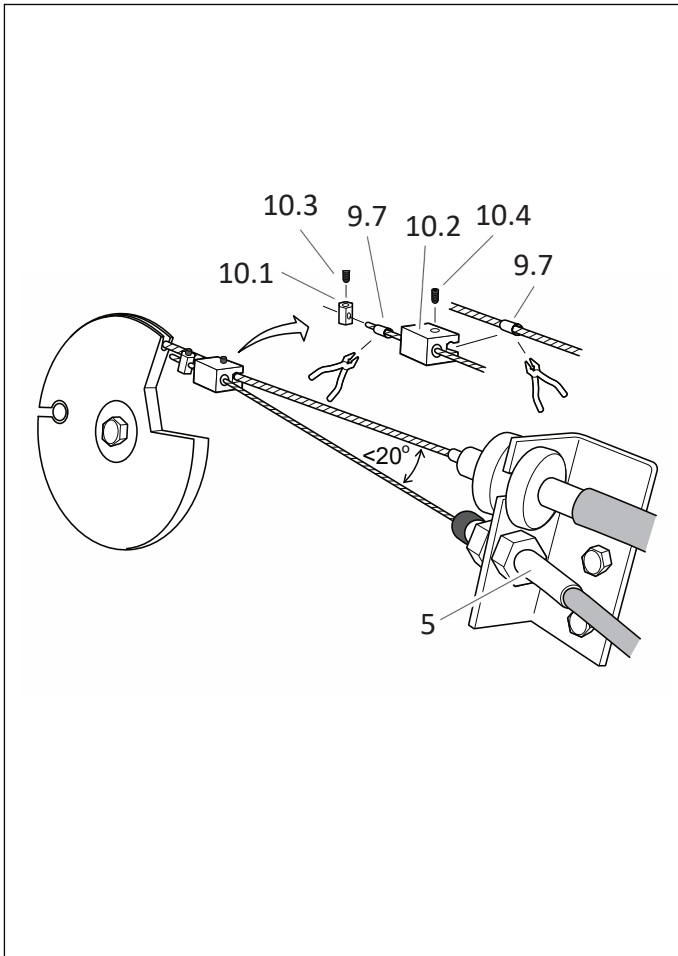

Determine the most suitable throttle linkage so that the angle between servo and throttle cable is less than 20° . Mount cable bracket 8.1 like described on ch. 3.1 or find an attachment point where bracket is not needed.

Find attachment location of cable clamp 10.2 taking into account instructions on ch. 3.1. Install metal clip 9.7 to the cable clamp installation location and press it with pliers around the throttle cable, install cable clamp 10.2 and fix it with bolt 10.4 so that bolt will press against metal clip.

After cable is attached to the servo, attach servo cable 5 to its attachment location, push the inner cable through the hole of cable clamp 10.2, install U shaped metal clip 9.7 to the location where will be installed end clamp 10.1 and press it with pliers around the inner cable, install end clamp 10.1 and fix it with bolt 10.3 so that bolt will press against metal clip.

3.3 Cable attachment to the throttle pedal

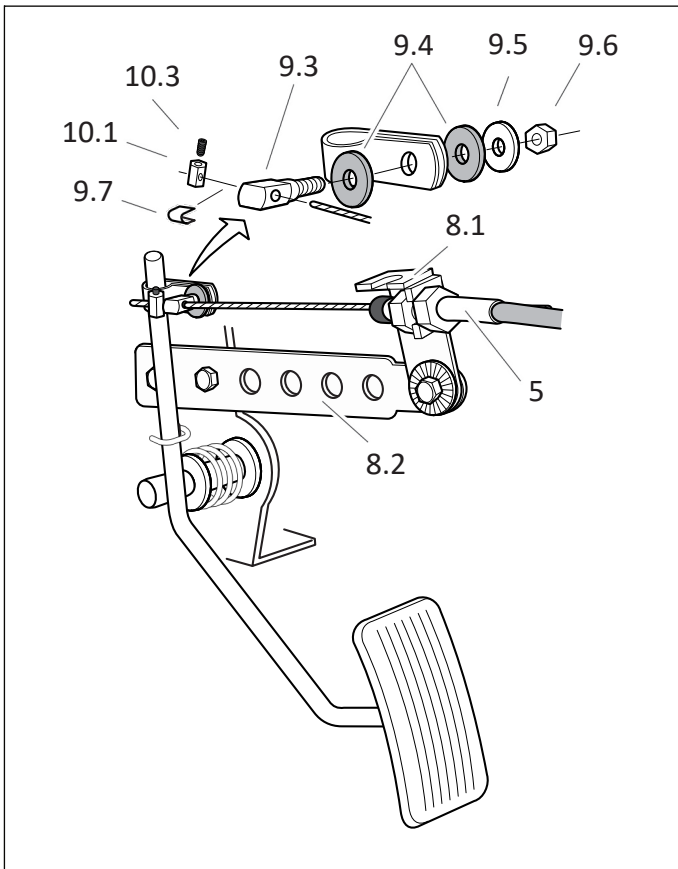

If throttle pedal have an idle contact, kick-down switch or electronic cruise control is not suitable, the servo cable should be mounted directly to the pedal.

Determine the most suitable throttle linkage. Mount cable bracket 8.1. It can be used as one piece or with extension 8.2 or bent and trimmed in numerous ways.

Install the swivel bolt 9.3 with nylon washers 9.4, washer 9.5 and lock nut 9.6 to the throttle pedal so that bolt could freely swivel allowing servo cable to slide straight through in any position of throttle mechanism.

After cable is attached to the servo, install servo cable 5, push the inner cable through the hole of swivel bolt 9.3 and install end clamp 10.1 according to instructions on ch. 3.2

4. SERVO INSTALLATION

4.1 Choosing the cable pulley and shortening the cable

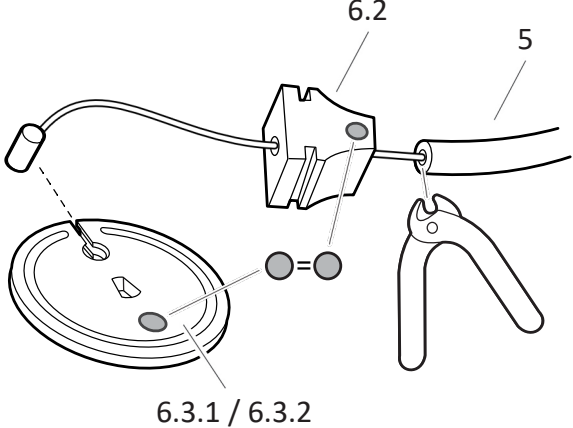
 <p>6.2</p> <p>5</p> <p>6.3.1 / 6.3.2</p>	<p>Use a caliper to determine the cruise control cable stroke A described in ch. 3.1. Based on this length, the choice of pulley to be used is made. Ideally, the stroke of the chosen pulley should be a few millimetres shorter than distance A.</p> <p>In the hardware kit, you will find 2 pulleys, parts 6.3.1 and 6.3.2. Each pulley can be mounted 2 ways. This gives you 4 options for the stroke of the servo cable:</p> <p>Pulley with red dot: 38 mm or 31 mm Pulley with yellow dot: 24 mm or 18 mm.</p> <p>Remove the inner cable of 5. If required, shorten the servo outer cable by cutting it at the servo side. Insert the servo outer cable into the triangular block 6.2. Insert the servo inner cable into the outer cable and insert the nipple of the inner cable into the pulley.</p>
--	--

4.2 Attaching cable and cable pulley to the electronic servo

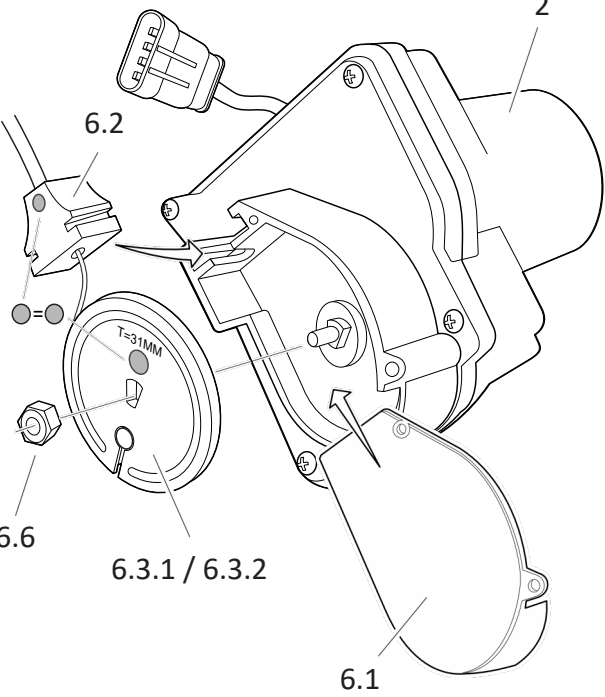
 <p>2</p> <p>6.2</p> <p>6.6</p> <p>6.3.1 / 6.3.2</p> <p>6.1</p>	<p>Place the pulley 6.3.1 or 6.3.2 on the axle of the electronic servo 2, with the written correct stroke size visible on the outside, secure it with the M6 lock nut 6.6. Install the cruise control cable with triangular plastic block 6.2 to the servo so, that the visible colour on it matches the colour on the pulley.</p> <p>Slide the cover 6.1 onto the servo in direction shown on the picture.</p>
--	---

4.3 Securing servo and connecting wiring harness

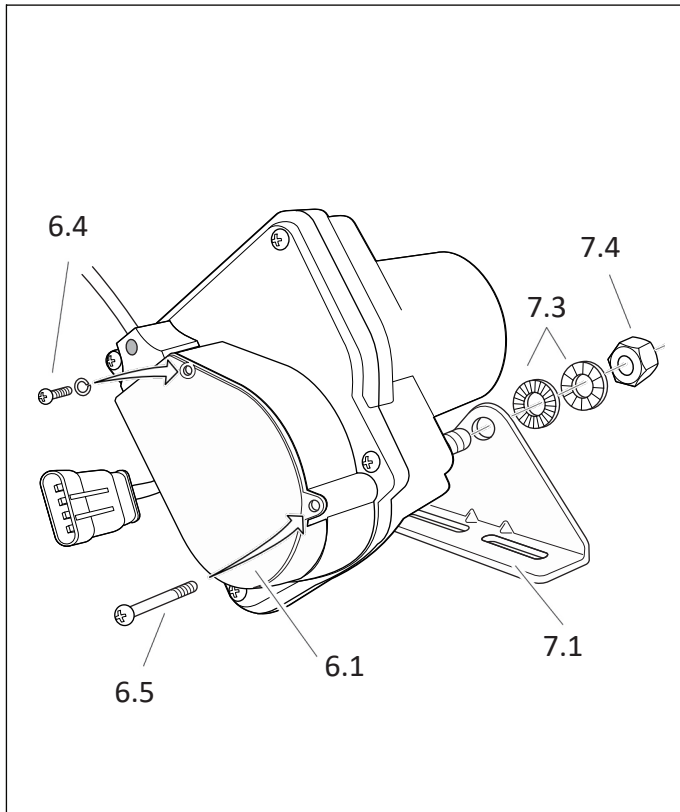

Fasten servo cover 6.1 it using the bolt with spring washer 6.4 and screw 6.5.

Attache the servo to vehicles body in the engine compartment where it can be fixed using one of the two black brackets 7.1 or 7.2. Secure servo to the bracket with the pair of lock washers 7.3 between the bracket and the M10 nut 7.4, with the large serrations of lock washers against each other and the small serrations on the outside.









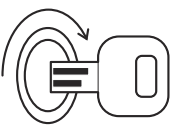
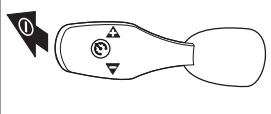

Connect the 4-pin plug to the servo harness 4, route harness through the bulkhead and connect to the main wiring harness following the colour code on the connector housing:
pos. 6: green/ red, pos.7: black,
pos. 16 pink/ red, pos. 17 blue/ red.

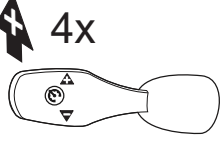
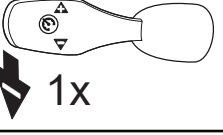

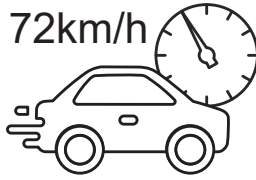



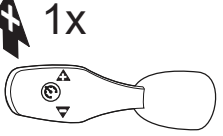

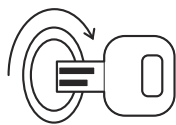
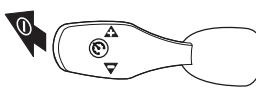

Warnings!

- The installer of the AP500 should be knowledgeable and experienced with contemporary automotive engineering and car electronics.
- Incorrect and/or inexpert installation, connection, setting and/or diagnosis can lead to malfunctions of the vehicle and/or the AP500 and affect road safety.
- Operating the clutch pedal should always disengage cruise control. Fit and connect a clutch switch if it is not already in the car.
- Always solder the connections and insulate them with good quality insulating tape.
- Always mount the electronics module in a place where heat, vibration and moisture are minimal such as under the dashboard.
- Install the servo in a location in the engine compartment where it can be securely attached to the vehicle body and where the servo is away from electronic components and excessive heat and water.
- After installation, always check the smooth operation of the throttle mechanism, throttle cable and servo cable by operating the throttle mechanism with your foot and by hand. The throttle cables must not be able to become blocked or entangled in any way, as this may result in the throttle/diesel pump not returning to idle!!!
- Some cars barely decelerate when the throttle is left slightly open. Always give the servo cable a little slack in the idle position, large enough for the servo to regulate back to idle in the self-diagnostics.

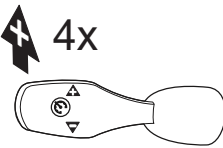
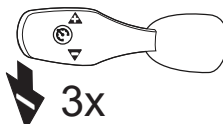
4. SPEED SIGNAL SETUP

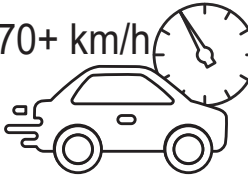
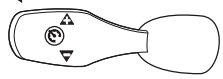
 Turn ignition on	 Push CM back to switch cruise control on	 Press and hold the BRAKE pedal	 Lift CM 4x up
 Press CM 1x down	 Release BRAKE pedal	 Drive 72 km/h	 Lift CM 1x up, cruise control will engage
<p>Go to the next step if cruise control takes over smoothly. If not adjust the reaction time *: to increase reaction time for 1 step lift CM 1x up, to reduce 1 step press CM 1x down</p>	 Press briefly BRAKE pedal	 Stop safely the vehicle	 Press and hold the BRAKE pedal
 Lift CM 1x up	 Release BRAKE pedal - setup completed	<p>* During speed calibration, the reaction time of switching on the Cruise Control can be adjusted directly. The reaction time is properly adjusted if the Cruise Control keeps the speed exactly constant when engaged.</p> <p>If the speed increases, reduce the reaction time by one step by pressing CM 1x down. If the speed decreases on activation, increase the reaction time by one step by lifting CM 1x up. There totally 14 steps of reaction time settings.</p> <p>Tap the brake briefly and activate Cruise Control again by lifting CM 1x up and test the reaction time again. Repeat this procedure if necessary.</p>	

5. ADJUSTING REACTION TIME Optional!

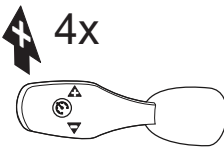
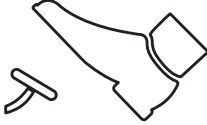
 <p>Turn ignition on</p>	 <p>Push CM back to switch cruise control on</p>	 <p>Press and hold the BRAKE pedal</p>	 <p>Lift CM 4x up ▲</p>
 <p>Press CM 3x down ▼</p>	 <p>Release BRAKE pedal</p>	 <p>Drive at least 70 km/h</p>	 <p>Lift CM 1x up ▲, cruise control will engage</p>
<p>The reaction time is properly adjusted if the cruise control keeps the speed exactly constant when cruise control takes over immediately when it engages after speed is set.</p> <p>If the speed increases when cruise control takes over, reduce the reaction time by one step by pressing CM 1x down ▼. If the speed decreases, increase the reaction time by one step by lifting CM 1x up ▲. There totally 14 steps of reaction time settings.</p> <p>Tap the brake briefly, enage cruise control again by lifting CM 1x up ▲ and test the reaction time again. Repeat this procedure if necessary. When adjusted go to next step.</p>			 <p>Press briefly BRAKE pedal</p>
 <p>Stop safely the vehicle</p>	 <p>Press and hold the BRAKE pedal</p>	 <p>Lift CM 4x up ▲</p>	 <p>Release BRAKE pedal - setup completed</p>

6. ADJUSTING SPEED SENSITIVITY Optional!

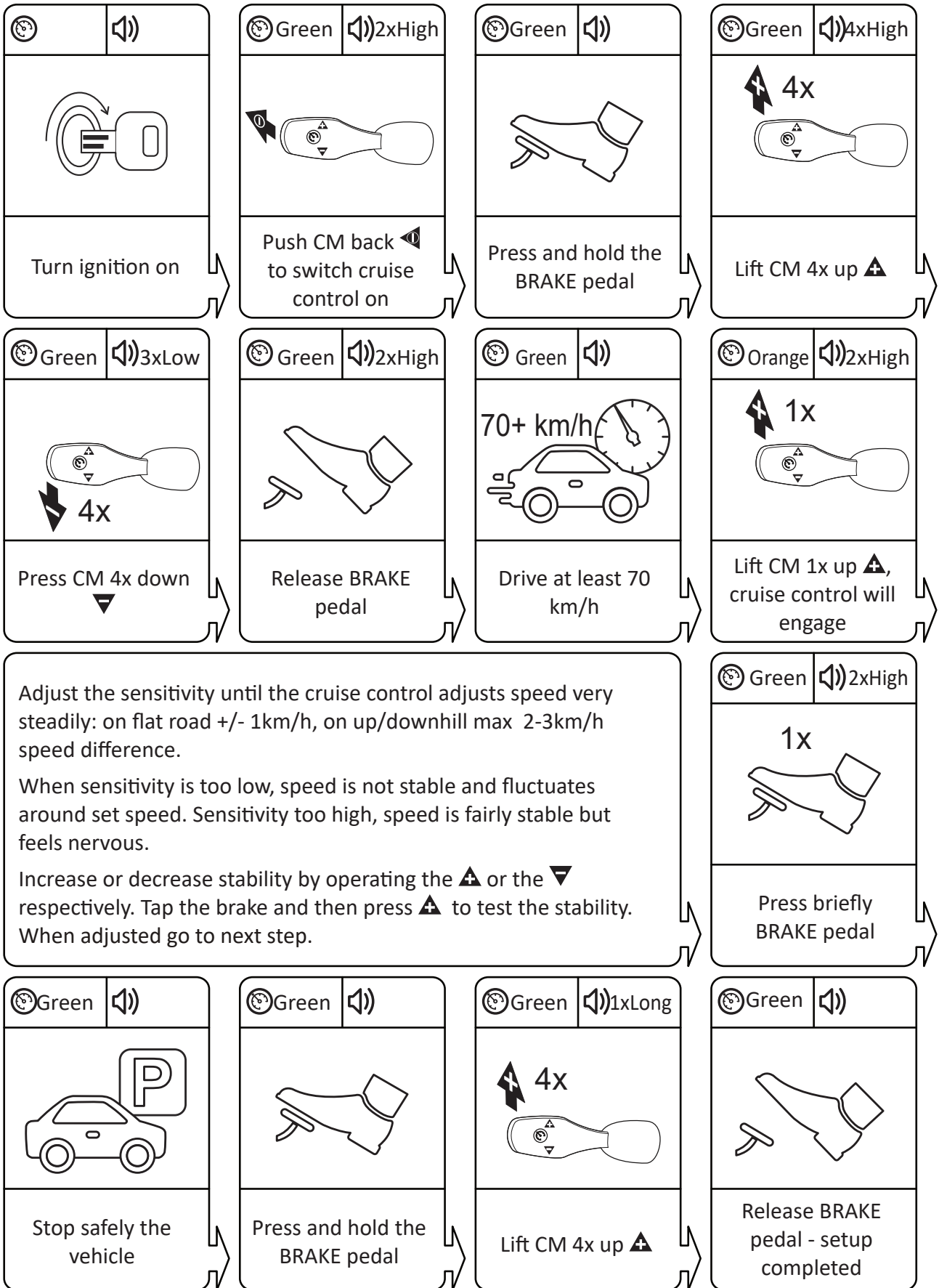

7. Diagnostics

7.1 Diagnostic 1: brake, clutch and command module test

Each operation produces a beep, if the sound is continuous, check CM and brake connections.

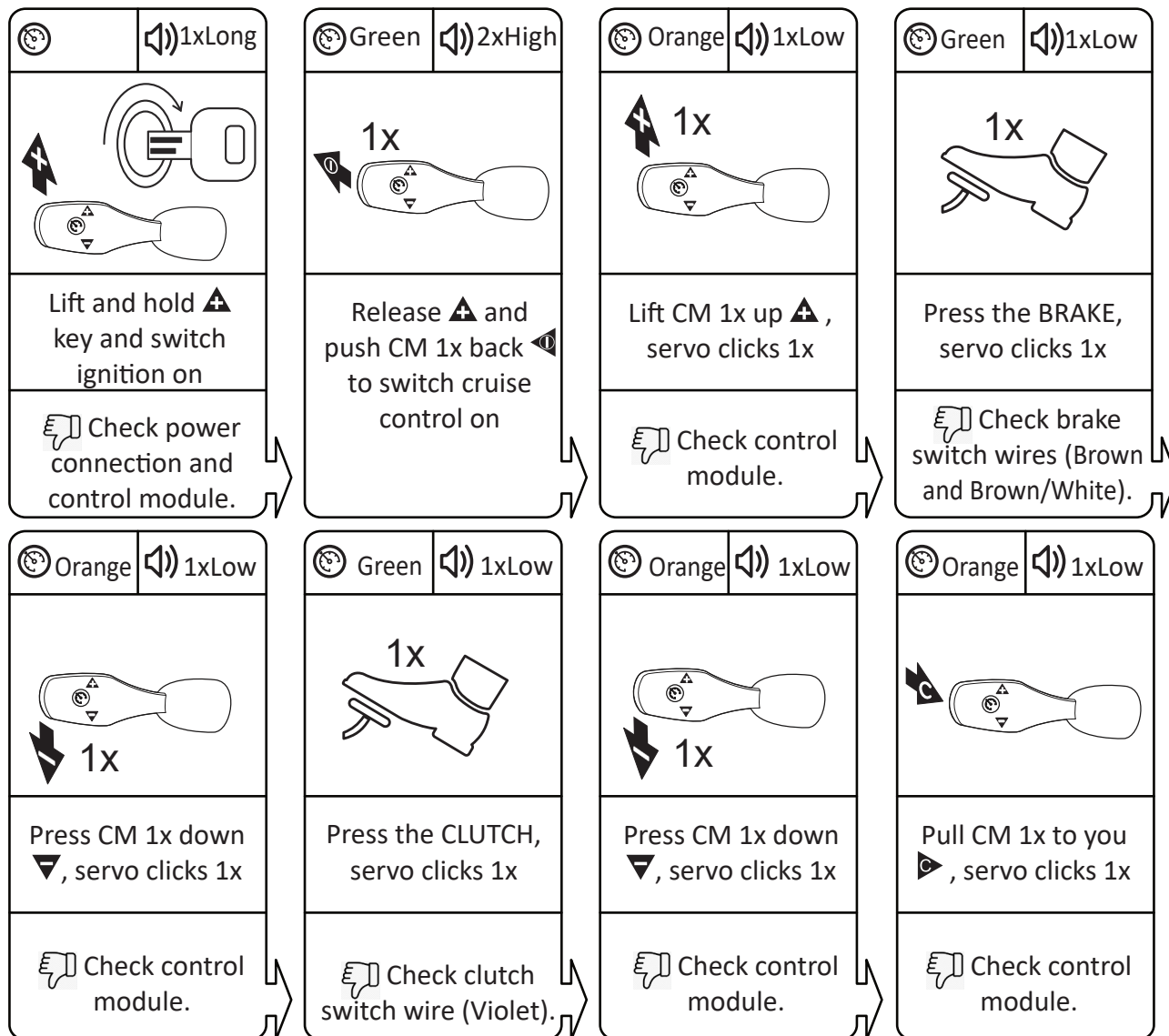

Signals of command module, * indicated voltages are during the corresponding function is operated with CM:

Wire	Function	CM Off	CM On	SET	RES	CANCEL	MEM I	MEM II
Black	Ground	Ground	Ground	Ground	Ground	Ground	Ground	Ground
Orange	Ignition 12V	Ignition 12V	Ignition 12V	Ignition 12V	Ignition 12V	Ignition 12V	Ignition 12V	Ignition 12V
Green	Cancel/LED	4.3V	4.3V	2.5V	2.5V	12V*	4.3V	4.3V
Red	LED	10.5V	8.3V	12V	12V	8.3V	8.3V	8.3V
Yellow	SET/RES	0V	0V	12V*	7V*	0V	0V	0V
Brown	On/Off	0V	12V*	0V	0V	0V	0V	0V
Blue	Memory	5V	5V	5V	5V	5V	2.75V*	4V*

Signals of brake and clutch wires:

Brown wire: normally grounded through brake lamps, +12V when brake pedal is pressed.
 Brown/ white wire: +12V
 Violet wire: switched to or away from ground when pressing the clutch pedal

7.2 Diagnostic 2: servo and speed signal test

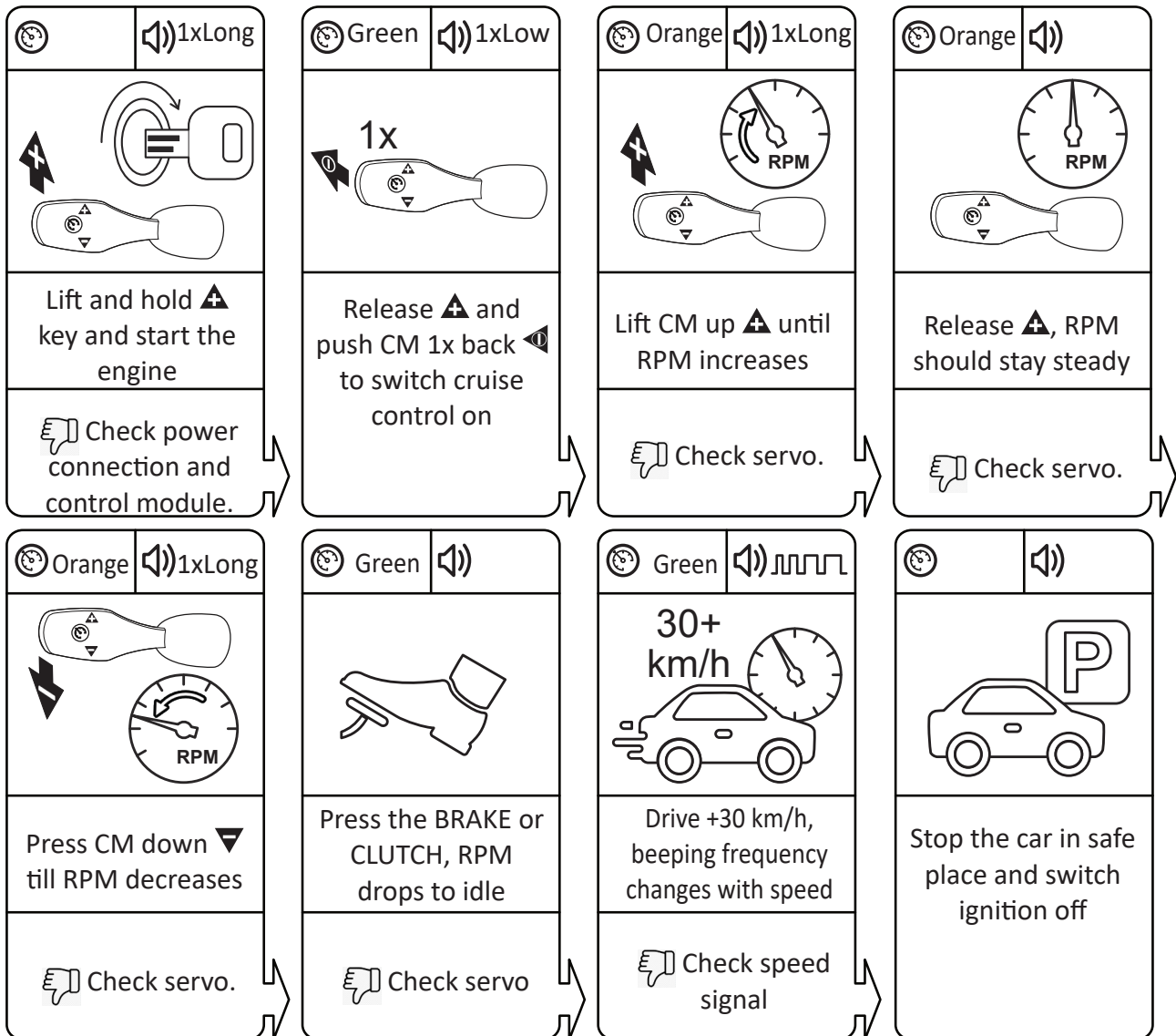

Diagnostic of servo:

- Unplug the connector of electronic module and locate servo wires: pos. 6: green/ red, pos.7: black, pos. 16 pink/ red, pos. 17 blue/ red. Check that there is no break in these wires by measuring the resistance between the servo and the connector.
- Useful are ignition +12V wire on pos. 15 orange and ground wire on pos. 6 green.
- Connect black wire to ground and green/ red wire to +12V: servo clicks 1x, if not it's faulty.
- Leave the power wires connected. Connect the pink/ red wire to ground and the blue/ red wire to +12V, servo pulls cable all the way in 1 go, if not it's faulty.

Diagnostic of speed signal:

- Check the speed signal using either a voltmeter or an oscilloscope. Make certain that the peak voltage of the ground signal is between -1.5v and -24v and is in the frequency range is 6Hz to 8.5KHz.
- If speed signal is weak then pull-up the signal: take a 10k - 20kOhm resistor, connect one end of the resistor to blue wire (speed signal) and the other to orange (ignition) of electronic module. If yellow wire is not connected then the noise suppressor on can be used for speed signal pull-up.

Zemco

www.zemco.eu

Version: 2.1